

Item	Description	HP Part No.	Qty
1	Flow Manifold Block, TCD and ECD	19232- 20500	1
2	O- Ring, 0.239- inch id package of 12	0905- 1014 5180- 4182	2 -
3	Restrictor, TCD Ref, Yellow	19232- 60650	1
4	Inlet Fitting	19231- 20560	2
5	Rear Clamping Plate	19231- 40010	1
6	Screw, M4 x 12 mm	0515- 0909	3
7	Restrictor, TCD Makeup Gas, Black	19232- 60610	1
8	Needle Valve Assembly (4 of Item 9 installed on each)	19231- 60650	2
9	Non- Greased O- Ring, 0.208- inch id "Viton" package of 12 package of 2, greased	0905- 0999 5061- 5867 5181- 1251	8 - -
10	Front Clamping Plate	19231- 40070	1
11	Mounting Screw, M4 x 45 mm long	0515- 0964	1
12	Outlet Fitting Plate	19231- 00060	1
13	Front Ferrule, Brass, 1/8- inch tube	0100- 0032	2
14	Back Ferrule, Brass, 1/8- inch tube	0100- 0036	2
15	Hex Nut, Brass, 1/8- inch tube	0100- 0058	2
16	Non- greased O- Ring, 0.114- inch id package of 12	0905- 1039 5180- 4181	3 -
17	Weldment, Makeup Gas	19232- 80550	1
18	Weldment, Reference Gas	19232- 80500	1

Figure 1. TCD Flow Manifold Block Assembly (Sheet 1 of 2).

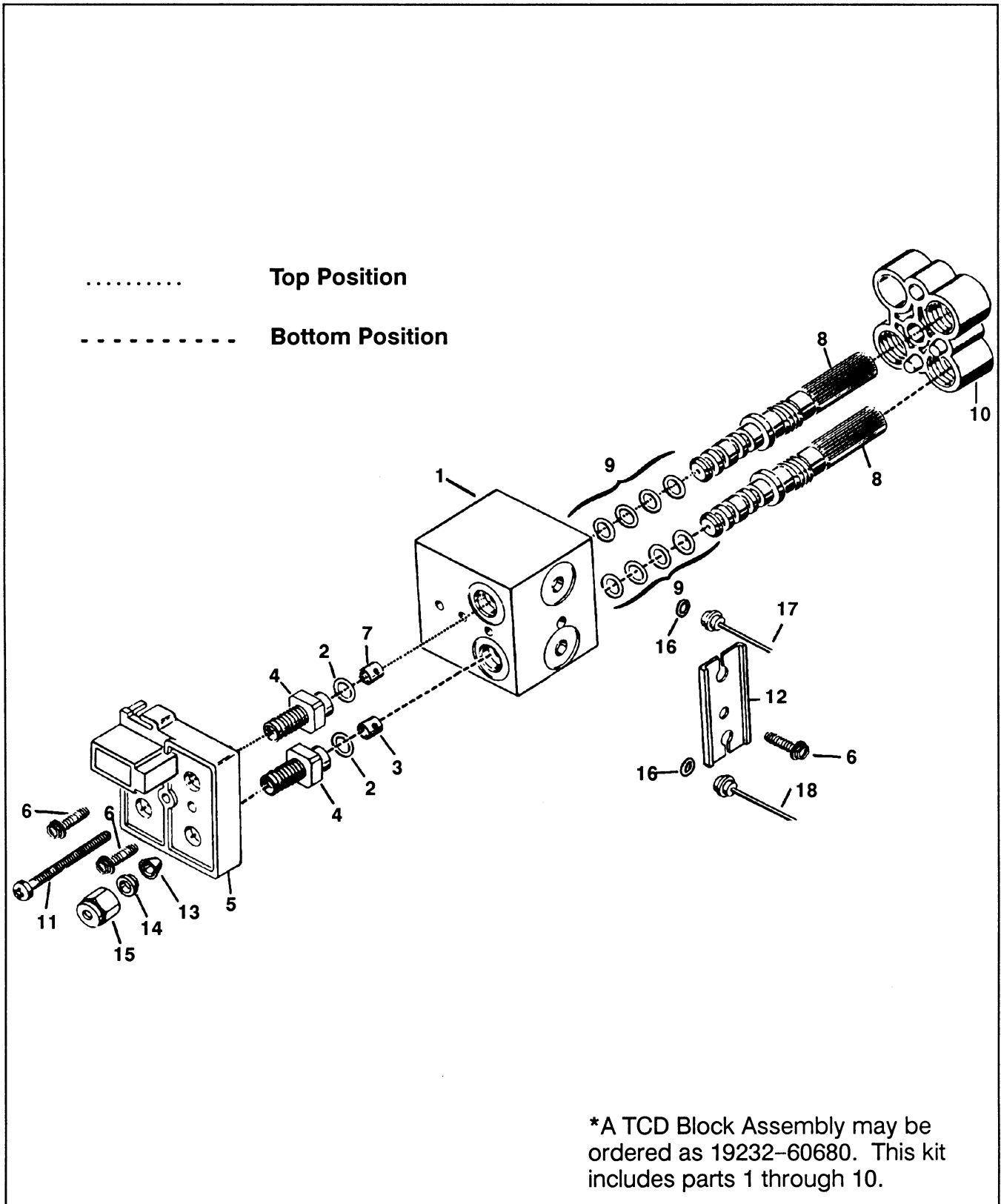

Figure 1. TCD Flow Manifold Block Assembly (Sheet 2 of 2).